

HYGIENE EQUIPMENT

COMPACT HYGIENE STATION WITH PASS-THROUGH (5 BRUSHES) BOOT CLEANING MACHINE 10.4021.00

The machine is designated for personal hygienic control when entering in and going out of working areas – cleaning of boots and disinfection of hands.

It consists of a hand disinfection unit with a turn style and pass-through boot cleaning machine.

The pass-through boot cleaning machine consists of five brushes with independent motor-gear each, injecting system of cleaning agent, automatic injector dosing of cleaning concentrate. The photocell at the entrance switches on the brushes (cleaning time is adjustable). When going out of working area, a second photocell unlocks the turn-style of 1/3 turnover and switches on the brushes.

The station can be left or right execution.

The turn style rotation can be one-way.

A programmable controller SIEMENS, allowing settings of operating modes in a wide range, is used for station control.

The machine complies with the Council Directives No. 2006/42/EC and 2006/95/EC and USDA regulations.



HYGIENE EQUIPMENT

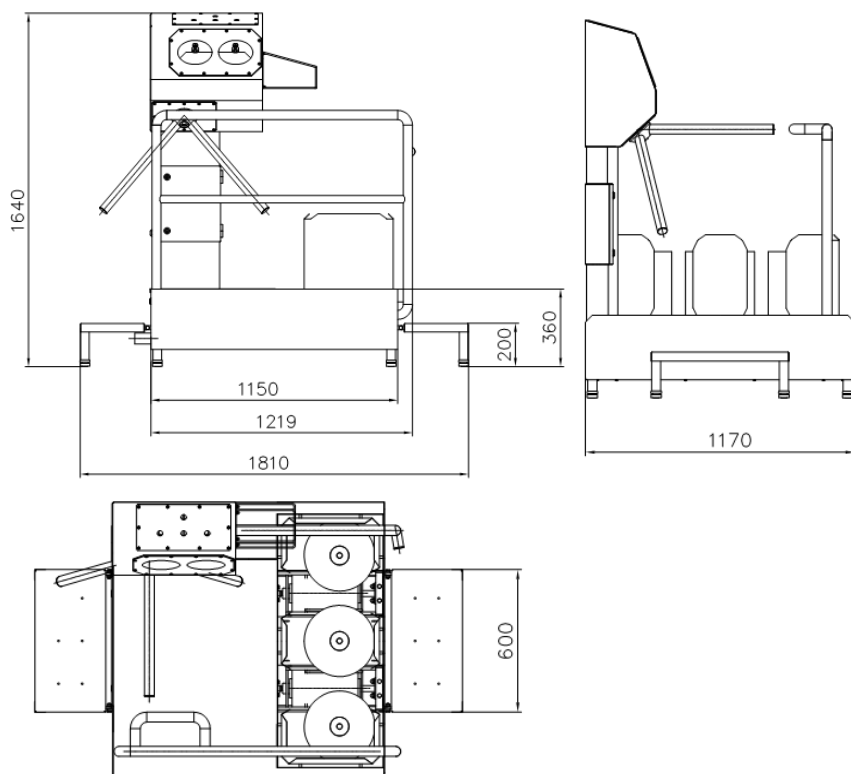

Technical data:

| | | |
|-----------------|---------|----------|
| Power supply | V/Ph/Hz | 400/3/50 |
| Control voltage | V | 24DC |
| Installed power | kW | ~ 1.1 |
| Water supply | bar | min 2 |
| Water outlet | mm | Ø50 |
| Weight | kg | ~180 |
| Passing time | sec | 6-8 |

Dimensions:

| | | |
|--------------------------------|----|----------|
| Length of body (without steps) | mm | 1150 |
| Total length | mm | 1810 |
| Length of sole brushes | mm | 300/Ø170 |
| Height of boot brushes | mm | 300/Ø280 |
| Total width | mm | 1170 |
| Total height | mm | 1640 |

HYGIENE EQUIPMENT



10.4031.00 – with boot cleaning



10.4221.55 – with disinfection bath

COMPACT HYGIENE STATION WITH PASS-THROUGH BOOT CLEANING MACHINE

| Art. No | 10.2021.00 | 20.2020.00 | 10.4021.00 | 10.4020.00 | 10.4031.00 | 10.4221.55 |
|---|---|------------|---|------------|---|---|
| Dimensions (L,W,H mm) | 1810/1170/1640 | | 1810/1170/1640 | | 2558/1350/1585 | 2610/1190/1630 |
| Hand disinfection unit/sink | yes/no | | yes/no | | yes/no | yes/no |
| Turn style/gate | yes/no | | yes/no | | yes/no | yes/no |
| Disinfection bath/drip-off zone | no/no | | no/no | | no/no | yes/yes |
| Brushes - soles length /boots height (mm) | 2x300/3x300 | | 2x300/3x300 | | 2x700/3x300 | no/3x300 |
| One-way/two-ways | one-way | | two-ways | | two-ways | one-way |
| Execution left/right | right | left | right | left | right | right |
| Ground fixation/wall installation | yes/no | | yes/no | | yes/no | yes/no |
| Passing time (sec) | ~ 8-10 | | ~ 8-10 | | ~ 12-14 | ~ 8-10 |
| Instaled power (kW) | ~1.1 | | ~1.1 | | ~1.2 | ~1 |
| Power supply - electricity/water/steam/compressed air/drain | 3x400 V / 50 Hz min. 2 bar water drain DN50 | | 3x400 V / 50 Hz min. 2 bar water drain DN50 | | 3x400 V / 50 Hz min. 2 bar water drain DN50 | 3x400 V / 50 Hz min. 2 bar water drain DN50 |
| Miscellaneous | | | | | with boot cleaning | with disinfection bath |