

HYGIENE EQUIPMENT

COMPACT HYGIENE STATION WITH SINK 10.4212.00

The machine is designated for personal hygienic control when entering in and going out of working areas. There is a guarantee hand washing before disinfection at entering in the working area.

The purpose of the hygienic station is to answer the increasing hands hygienic requirements to manufacture workers. The whole process of entering in and going out may be controlled and programmed as a succession.

It consists of a sensor operated (photocell) hand sink with an automatic soap dispenser, hand disinfection unit with turn style, pass-through sole cleaning machine and active (automatic level support) sole disinfection bath.

The machine complies with the Council Directives No.98/37/EEC and 73/23/EEC and USDA regulations.

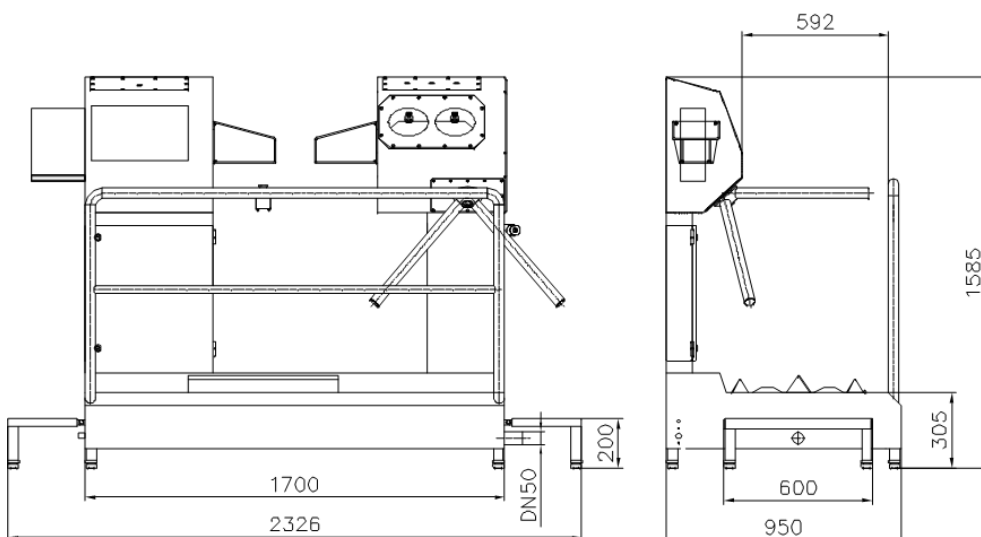

HYGIENE EQUIPMENT

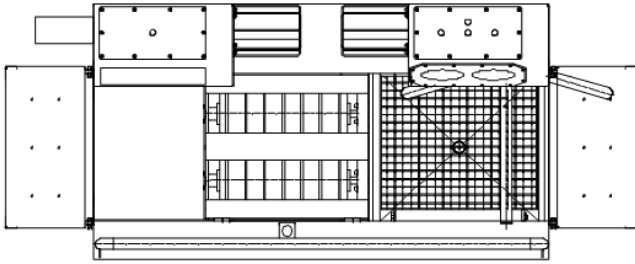

Technical data:

Power supply	V/Ph/Hz	400/3/50
Control voltage	V	24DC
Installed power	kW	~ 0.7
Water supply	bar	min 2
Water outlet	mm	Ø50
Weight	kg	~250
Passing time	sec	12 - 14

Dimensions:

Length of body (without steps)	mm	1700
Total length	mm	2326
Length of brushes	mm	500/Ø170
Width	mm	950
Height	mm	1585



10.4013.50 – brushes 500 mm

HYGIENE EQUIPMENT



10.4013.50 – with 500 mm brushes



10.4212.00 – with towel dispenser and waste basket



10.4033.03 – sink, hands dryer, independant module for boot cleaning



10.4013.55 – without turn style



10.4012.51 - without turn style, step opposite of the sink

HYGIENE EQUIPMENT

COMPACT HYGIENE STATION WITH SINK

Art. No	10.4212.00	10.4213.00	10.2212.00	10.2213.00	10.4012.00	10.4013.00	10.4012.50	10.4013.50
Dimensions (L,W,H mm)	2326/950/1585		2326/950/1585		2060/930/1585		1860/950/1585	
Hand disinfection unit/sink	yes/yes		yes/yes		yes/yes		yes/yes	
Turn style/gate	yes/no		yes/no		yes/no		yes/no	
Disinfection bath/drip-off zone	yes/no		yes/no		no/no		no/no	
Brushes - soles length /boots height (mm)	2x500/no		2x500/no		2x700/no		2x500/no	
One-way/two-ways	two-ways		однопосочна		two-ways		two-ways	
Execution left/right	left	right	left	right	left	right	left	right
Floor fixation/wall installation	yes/no		yes/no		yes/no		yes/no	
Passing time (sec)	~ 14-16		~ 14-16		~ 14-16		~ 12-14	
Instaled power (kW)	~0.9		~0.9		~0.7		~0.7	
Power supply - electricity/water/steam/compressed air/drain	3x400 V / 50 Hz min. 2 bar water drain DN50		3x400 V / 50 Hz min. 2 bar water drain DN50		3x400 V / 50 Hz min. 2 bar water drain DN50		3x400 V / 50 Hz min. 2 bar water drain DN50	
Miscellaneous								

Art. No	10.4033.03	10.4012.53	10.4012.51	10.4013.55	10.4013.18
Dimensions (L,W,H mm)	2454/1483/1640	2050/950/1570	1860/950/1585	1826/950/1600	2125/1030/1570
Hand disinfection unit/sink	yes/yes	yes/yes	yes/yes	yes/yes	yes/yes
Turn style/gate	yes/no	yes/no	no/no	no/no	yes/no
Disinfection bath/drip-off zone	no/no	no/no	no/no	no/no	no/no
Brushes - soles length /boots height (mm)	2x700/3x300	2x500/no	2x500/no	2x500/no	2x1000/no
One-way/two-ways	two-ways	two-ways	two-ways	two-ways	two-ways
Execution left/right	right	left	left	right	right
Floor fixation/wall installation	yes/no	yes/no	yes/no	yes/no	yes/no
Passing time (sec)	~ 12-16	~ 12-16	~ 12-14	~ 12-14	~ 12-16
Instaled power (kW)	~1.3	~2.3	~0,7	~0,7	~2.3
Power supply - electricity/water/steam/compressed air/drain	3x400 V / 50 Hz min. 2 bar water drain DN50	3x400 V / 50 Hz min. 2 bar water drain DN50	3x400 V / 50 Hz min. 2 bar water drain DN50	3x400 V / 50 Hz min. 2 bar water drain DN50	3x400 V / 50 Hz min. 2 bar water drain DN50
Miscellaneous	empty space for hands drying; independant module for boot cleaning	empty space for hands drying; water entrance and exit is at the same side	without turn style, step opposite of the sink	without turn style	empty space for hands drying; all connections are at the same side